

# Barrier-Free Building

Access for All

Planning Documents for Automatic Doors



Sales partner/contact:

[ ]

[ ]

# Contents

<b>Open the Doors to a Barrier-Free World</b>	<b>3</b>
<b>User Groups</b>	<b>4</b>
<b>Recommendations for Fitting-Out</b>	<b>6</b>
<b>Passageways with Swing Doors</b>	<b>10</b>
<b>Passageways with Sliding Doors</b>	<b>12</b>
<b>Passageways Turnstile Revolving Doors</b>	<b>14</b>
<b>Passageways with Folding Doors</b>	<b>16</b>
<b>Designing for Bath-Rooms and Toilets</b>	<b>18</b>
<b>Emergency and Escape Routes / Fire Protection</b>	<b>20</b>
<b>Additional Documentation</b>	<b>22</b>
<b>Planning and Consultancy</b>	<b>22</b>

Acknowledgement  
Pictograms on the title page:  
anatom5 GmbH, Natko e.V.

Printed on FSC certified paper

# Open the Doors to a Barrier-Free World

Good architecture does not just appeal to the eye and other senses. It also allows people to move without restrictions, to take part in the life of a society and to be able to work efficiently.

With its automatic door systems, TORMAX makes a major contribution to an architecture which impresses both due to its aesthetic qualities as well as its functionality. But features which primarily signify comfort and efficiency for people without a handicap are indispensable for others if they are to have the ability to go about their daily lives. TORMAX has therefore set itself the objective of making access to buildings and, once inside them, moving around the building safe and comfortable for all – very much with the guiding principle of “doors you do not notice” There are hundreds of thousands of our systems installed across the world in the widest possible range of buildings. Every day these open a million times over – quickly, safely and quietly – in hotels, exhibition centres, shopping malls, in care homes and hospitals, in commercial and residential buildings.

Right from the beginning TORMAX has paid particular attention to safety in the operation and use of its door systems – which is also why we attach major importance to meeting the requirements of user groups with restricted mobility. These groups are particularly:

- senior citizens
- people with walking disabilities
- wheel-chair occupants
- people with hand and arm disabilities
- the partially sighted
- the blind
- people with impaired hearing or who are profoundly deaf
- children and people of short stature

This is precisely the reason why we have prepared this brochure. It is intended to provide architects and planners with a valuable planning and construction tool when designing barrier-free buildings. The documentation concentrates on those aspects which are most important for planning automatic door systems. It also enables the reader to get to know and exploit what can truly be described as the almost boundless possibilities of our systems for barrier-free building. Last but not least, early reference to these guidelines will save you from a major part of the incremental costs of barrier-free building.

## Reference to standards

Significant parts of this planning document follow the requirements of the following standards:

- DIN 18040-1, Barrier-free Building, Part 1: Buildings Accessible to the Public
- DIN 18650-1, Locks and Architectural hardware, Automatic Door Systems – Part 1: Product Requirements and Testing Procedures
- DIN 18650-2, Locks and Architectural Hardware, Automatic Door Systems – Part 2: Safety in Automatic Door Systems
- BGR 181, BG rules on floors with slip hazards in buildings, workshops and working areas accessible to the public

The documentation can help you in your planning work with valuable tips and information. However, it cannot replace the laws and regulations applicable in the country where your project is located. We wish to point out expressly that it is the responsibility of planners, architects and engineers to incorporate and comply with the regulations applicable to their projects.

We look forward to joining with you in planning – and opening – the doors to a barrier-free world.

## Note

In order to make this planning document easy to read and understand, we have used only the masculine form when referring to persons. However, all references and personal designations apply equally to both sexes.

# User Groups

Limitations in everyday use, space requirements

## Senior Citizens

Older people are confronted with a multiplicity of barriers in their everyday life. For example, the faculties of the senses decline significantly: vision dims, eyes adapt to changes from light to dark (and vice versa) more slowly, hearing declines, fine motor skills – the precision of arm and leg movements – deteriorate, walking over long distances becomes difficult. As a result of this decline in their faculties, older people become more readily stressed which is why clear signage makes their daily life much easier

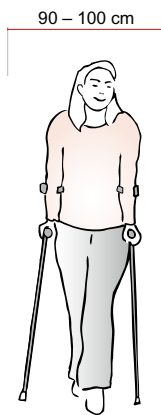

## People with Walking Disabilities

People with walking disabilities can often only move about with walking aids. They are slower than healthy persons and walking is often associated with great effort. People with walking disabilities are usually older people; the requirements of barrier-free building for senior citizens are therefore often the same as those for people with walking disabilities.

## Wheel-Chair Users

The biggest obstacles in the everyday life of wheel-chair users are cramped spaces, thresholds and steps. A building which is “wheel-chair friendly” provides sufficient space and clearance for access to rooms and for turning. The increasingly popular wheel-chair “tractors” or electrically driven wheel-chairs need more space than conventional wheel-chairs.

Space required for turning:  
90 degree turn: 140 × 140 cm  
180 degree turn: 140 × 170 cm

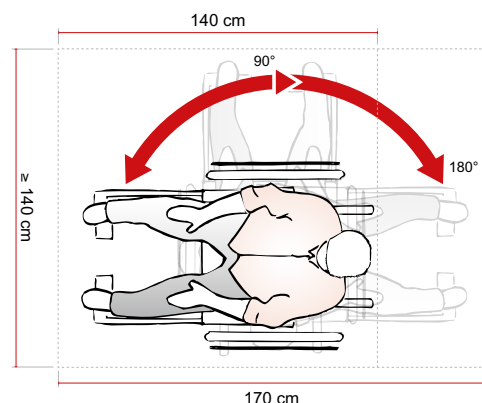

## People with Arm and Hand Disabilities

People with arm and hand disabilities have only limited use of their arms and hands. Lack of muscle power, disabilities such as trembling or difficulty in coordinating as well as missing or malformed limbs give rise to difficulties when grasping, touching or pressing operating switches or buttons.

## The Partially Sighted

Partially sighted people have only a limited visual perception of their environment and hazards. Depending on the severity of their disability, their field of vision and/or eye-sight, range and sharpness of vision are seriously impaired.

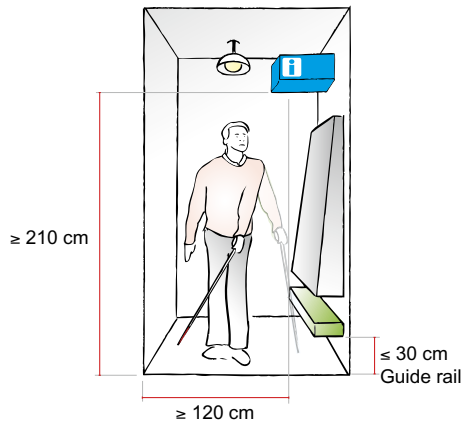

## Blind People

The blind have to rely primarily on their hearing and sense of touch if they are to move about in their daily life. Information should therefore comply with the “two senses principle” and be accessible to at least these two senses.

## People with Impaired Hearing and the Profoundly Deaf

People with impaired hearing or who are profoundly deaf are very reliant on their sense of vision because of their lost or impaired hearing. Special attention should therefore be paid to optical aids when planning entrances or passageways.

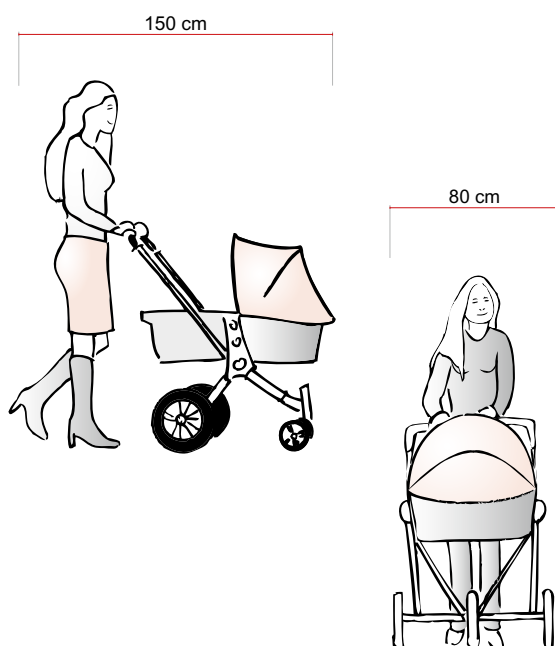

## Children and People who are Short of Stature

Anyone pushing a pram or children’s buggy is faced with similar problems as the wheel-chair user with regard to space and the ability to move about. Minimum dimensions should therefore also be based on the information in the section on wheel-chair users.

Children are unpredictable. They move more slowly than adults but can suddenly run off if something attracts their attention as they are easily and spontaneously distracted. Their movements are still uncoordinated – they do not see glass doors and normally cannot yet properly assess speeds and dangers such as rotating or closing doors.

People who are short of stature often cannot reach operating controls which are installed too high for them.

# Recommendations for Fitting-Out

## User groups

Senior citizens	People with walking disabilities	Wheel-chair users baby buggy	People with arm and hand disabilities	The partially sighted	Blind people	People with im-paired hearing and the profoundly deaf	Children and people who are short of stature
-----------------	----------------------------------	------------------------------	---------------------------------------	-----------------------	--------------	---	--

## Automatic doors

Sliding doors	•	•	•	•	•	•	•
Swing doors	•	•	•	• (1)	-	•	• (3)
Folding doors	•	•	•	•	•	•	•
Turnstile revolving doors	• (1)	• (1)	• (2)	• (3)	-	•	• (3)

1) limited suitability 2) 3 leaf doors from Ø 3400 mm, 4 leaf doors from Ø 3600 mm and completely protected 3) only when completely protected

		Standards (page 3): Germany	Notes
<b>1</b>	<b>Automatic doors</b>		
	<b>For all doors</b>		
	Unobstructed width	≥ 90 cm	
	Unobstructed height over finished floor level	≥ 205 cm	
	Absolutely uninterrupted and step-free access	X	
	<b>In front of swing doors (see figure 1)</b>		
	Movement area on the opening side	≥ 150 cm × ≥ 150 cm	
	Movement area on the opposite side	≥ 120 cm (w) × ≥ 150 cm (d)	
	<b>In front of sliding doors (see figure 2)</b>		
	Movement area on both sides	≥ 190 cm (w) × ≥ 120 cm (d)	

<b>2</b>	<b>Control devices</b>		
	<b>For all doors</b>		
	Shape which is easily gripped and adequately dimensioned	X	
	Configured with a strong visual contrast	X	
	Must be able to be reached without steps	X	
	Must be obvious	X	
	Height (middle of button) over finished floor level	85 cm	
	Force to be applied to activate	2.5 – 5.0 N	
	No sensor buttons, touch-screens	X	
	Feedback that function is triggered	auditory acknowledgement/ switch position	
	Two senses principle (touch and vision)	X	
	Locate horizontally aligned with each other	X	
	Large characters on buttons, in braille or relief (blind persons user group)	X	
	Optical signals (flashing / different colour codes), clear switch position (people with impaired hearing or the profoundly deaf user group)	X	
	<b>For swing doors (see figure 1)</b>		
	Clearance in opening direction with frontal approach	≥ 250 cm	
	Clearance to main closing edges	≥ 50 cm	
	Clearance in closing direction with frontal approach	≥ 150 cm	

<b>For sliding doors (see figure 2)</b>			
Clearance on both sides with frontal approach		≥ 150 cm	
<b>3 Safety marking / on-site colour scheme</b>			
<b>On all glazed doors (see figures 1 and 2)</b>			
Distinct and contrasting colour		light/dark	
Glass fronts and all thresholds must be very clearly marked		X	
Height of marking above finished floor level		40 cm – 70 cm and 120 cm – 160 cm	
Height of marking (in form of a stripe)		Ø 8 cm	
Proportion taken up by the stripe		≥ 50 %	
<b>For swing doors (see figure 1)</b>			
Floor marking in the opening direction		X	
<b>For sliding doors (see figure 2)</b>			
Clearly differentiate moving and fixed glass surfaces		X	

Figure 1  
Relevant dimensions and markings  
for swing doors

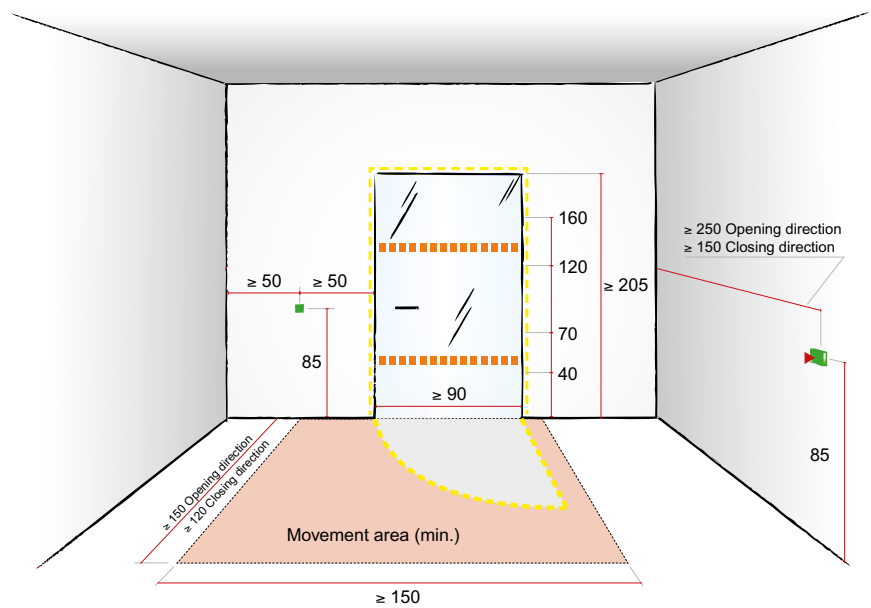
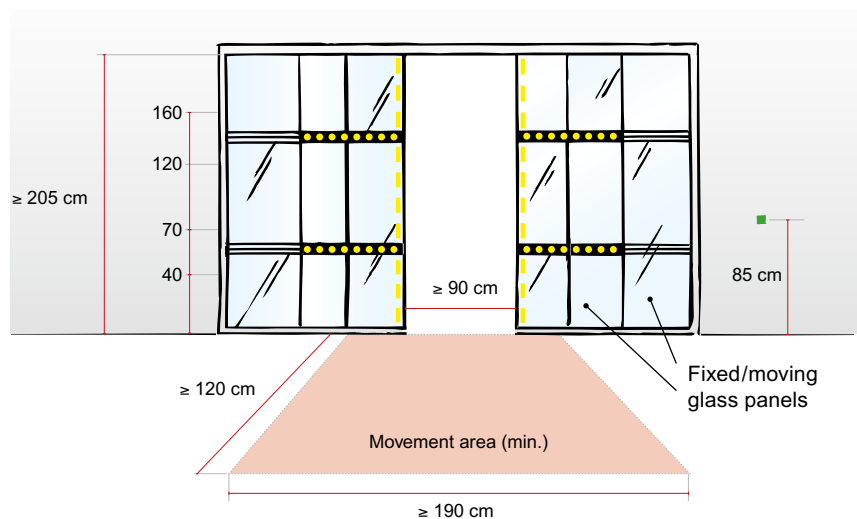

Figure 2  
Relevant dimensions and markings  
for sliding doors



4 Floor covering			
	Low reflectivity, high contrast	X	
	Level and hard, non-skid	X	
	Firmly fixed in place. Must not distort when a wheel-chair turns	X	
	Longitudinal slope, if unavoidable	≤ 3%	
	Transverse slope, if unavoidable	≤ 2%	
	Walking aids must not cause any indentations	X	

5 Illumination			
<b>Corridors</b>			
	Light colour	warm white/neutral white	
	Type of illumination	direct/indirect	
<b>Waiting, recreation, living, common rooms</b>			
	Light colour	warm white/neutral white	
	Type of illumination	direct/indirect	
<b>Bath/WC</b>			
	Light colour	warm white/neutral white	
	Type of illumination	direct/indirect	

6 Hand-rails			
	High hand-rails, double hand-rails better	85 cm – 90 cm	
	Arrangement of hand rails on stair-cases	on both sides	
	Tapering hand-rails at beginning and end	≥ 30 cm horizontal	
	Hand-rails engraved with floor number	X	
	Labelling on hand-rails at beginning and end	in braille and tactile Latin letters (e.g. I.L.I.S profile script)	

7 Staircases			
	Warning surfaces before top and bottom of the stairs	X	
	High-contrast marking of all individual steps	<ul style="list-style-type: none"> <li>• continuous stripes on treads</li> <li>• begin directly on the front edge of the treads</li> <li>• between 4 and 5 cm wide</li> <li>• width on the front face (riser) 1 cm – 2 cm</li> </ul>	

8 Ramp			
	Width	≥ 120 cm	
	Slope	≤ 6 %	
	Edged and a level area every 6 m	150 cm × 120 cm	

9 Halls (escape routes)			
	Width (unobstructed)	≥ 150 cm	





# Passageways with Swing Doors

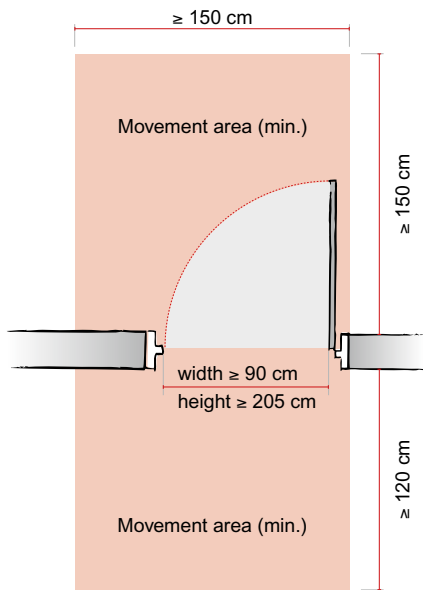

Entrance/exit

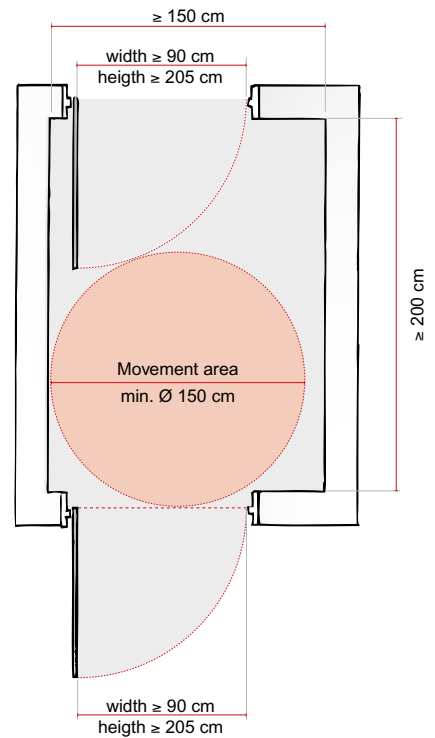

"Air locks"

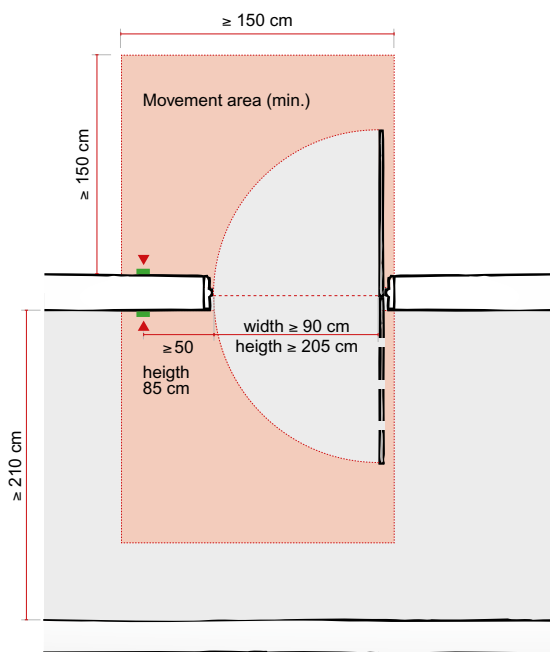

Corridors

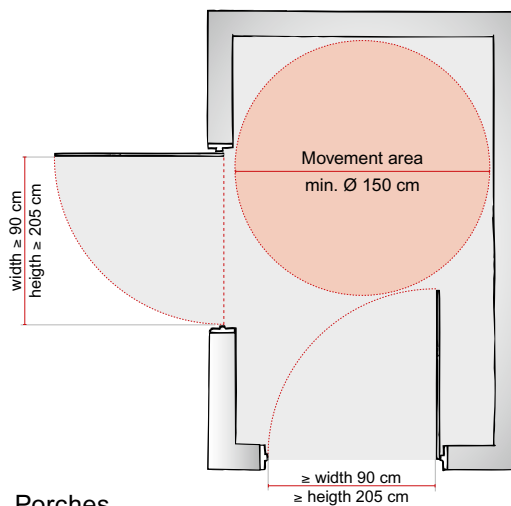

Porches

## Safety/Sensor Technology

Impulse fields and hazardous areas where protection is needed



- 1 Secondary closing edge
- 2 Main closing edge
- 3 Moving safety feature
- 4 Safety field
- 5 Impulse field

# Automated Door Equipment

Product/drive	Suitability/special features
iMotion 1401 swing door drive	<ul style="list-style-type: none"> <li>• External and internal doors, air locks, panic doors, smoke extraction doors.</li> <li>• Drive invisible in floor, integral linkage, sliding lever with panic fitting.</li> <li>• High opening and closing speed, high pedestrian frequencies.</li> <li>• Heavy door leaves (max. 450 kg at 1 m door width)</li> </ul>
iMotion 1301 swing door drive	<ul style="list-style-type: none"> <li>• External and internal doors, air locks, panic doors, smoke extraction doors.</li> <li>• Linkage (push), sliding lever (pull), sliding lever with panic fitting.</li> <li>• High opening and closing speed, high pedestrian frequencies.</li> <li>• Medium-heavy door leaves (max. 250 kg at 1 m door leaf width)</li> </ul>
Smart Drive 1101 swing door drive	<ul style="list-style-type: none"> <li>• Light internal doors, panic doors.</li> <li>• Linkage (push), sliding lever (pull).</li> <li>• Medium opening and closing speed.</li> <li>• Light to medium-heavy doors (max. 120 kg at 1 m door width)</li> </ul>

## Installation Information

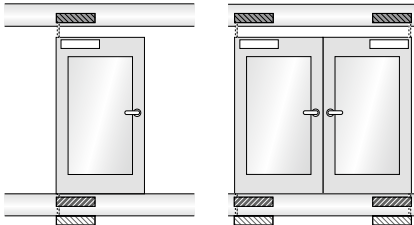
<b>Basic principles</b>	<ul style="list-style-type: none"> <li>• The system must be commissioned at least in accordance with DIN 18650 and only by an installation specialist trained by the manufacturer.</li> </ul>
<b>Drive installation</b>	<div style="display: flex; align-items: center;">  <div style="margin-left: 20px;"> <p><b>iMotion 1301, Smart Drive 1101:</b></p> <ul style="list-style-type: none"> <li>• drive on the lintel (push)</li> <li>• drive on the door leaf (push)</li> <li>• Avoid direct exposure of the automated door equipment to sun, snow and rain</li> </ul> <p><b>iMotion 1401:</b></p> <ul style="list-style-type: none"> <li>• drive in the floor (without linkage)</li> <li>• drive on the ceiling of the lower level (without linkage)</li> </ul> </div> </div>
<b>Power connection</b>	<ul style="list-style-type: none"> <li>• 1 × 230/1 × 115 VAC (+5 %/–10%), 50–50 Hz, 10 A.</li> <li>• Install the power plug directly adjacent to the drive.</li> <li>• Connection uses a commercial power cable with a connector for non-heating apparatus.</li> <li>• Only use earthed/grounded connectors.</li> <li>• The mains cable must be secured against becoming tangled with the moving parts of the drive or door system.</li> <li>• Connect 24 VDC directly to the door control system.</li> <li>• Adjust all necessary components to the maximum available power during the planning process. Provide an additional external 24 V power supply if additional power is needed.</li> <li>• Provide optional battery unit for power failures.</li> </ul>
<b>Safety</b>	<ul style="list-style-type: none"> <li>• Reduce speeds to avoid surprising users.</li> <li>• Control system with integral obstacle recognition in order to avoid serious injuries if the sensor system should fail.</li> <li>• Emergency and escape routes/fire protection – see page 20.</li> </ul>
<b>Protection against the main closing edge</b>	<ul style="list-style-type: none"> <li>• Motion detectors must cover the entire area in front of the door so that persons can be detected in good time and without contact in order to avoid endangering persons with poor reaction capabilities (possibly with additional moving safety sensors).</li> </ul>
<b>Protection against the secondary closing edge</b>	<ul style="list-style-type: none"> <li>• A finger guard (roller blind) is recommended for use with the secondary closing edges. This will prevent a blind person's stick or a child's fingers from being trapped.</li> </ul>
<b>Operation</b>	<ul style="list-style-type: none"> <li>• Maximum cable length from drive to button, key switch or user interface 30 m.</li> <li>• Do not install close to any secondary closing edge safety features.</li> </ul>
<b>Door leaves</b>	<ul style="list-style-type: none"> <li>• Door fillings: various glasses (toughened safety glass, laminated safety glass and insulating glass), wood, metal and plastic. Door leaves can be framed by profiles – clear anodised, stove enamelled or powder coated in any required colour.</li> <li>• Transparent door panels considerably lower the risk of accidents caused by collisions.</li> </ul>

# Passageways with Sliding Doors

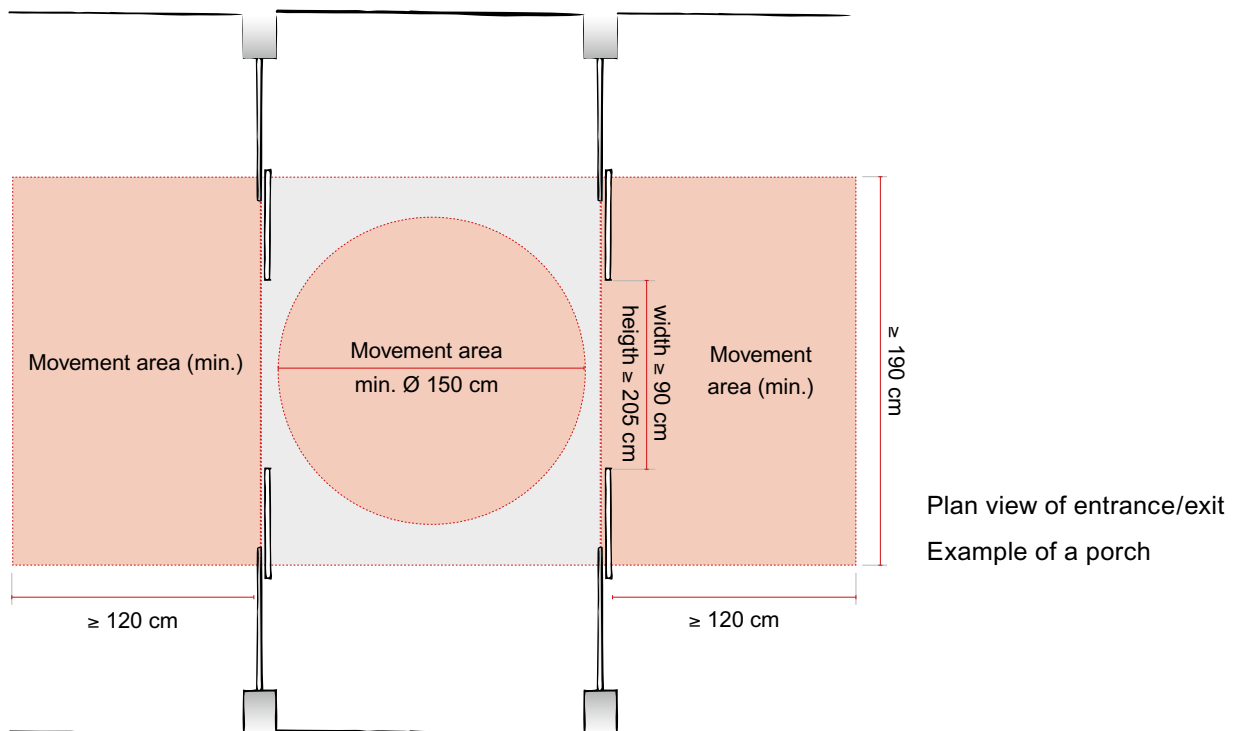

## Safety/Sensor Technology

Impulse fields and hazardous areas where protection is needed

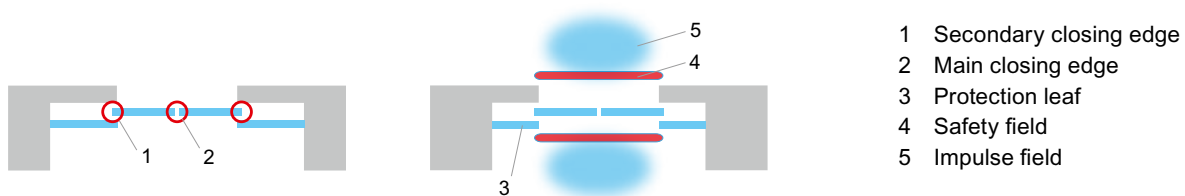

## Door Designs

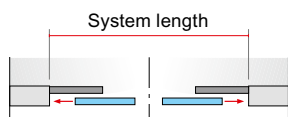

### Standard, 1 leaf, 2 leaves

Limited space  
Standard requirements



### Telescope, 2 leaves, 4 leaves

Maximum passageway  
when space is limited;  
maximum unrestricted width

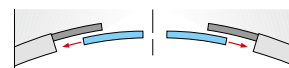

### Arc, 1 leaf, 2 leaves

Design-based, elegant entrances;  
prestigious, generously dimensioned  
lobbies

### Minimum system length (mm)

Standard	1 leaf	2 leaves
Win Drive 2201	1890	1950
iMotion 2301	1840	1880
iMotion 2401	1840	2280

Telescope	2 leaves	4 leaves
	1540	2570
	1467	2260
	1467	2260

# Automated Door Equipment

Product / drive	Suitability / special features
	<ul style="list-style-type: none"> <li>All drives are suitable for all door designs.</li> </ul>
Win Drive 2201 sliding door drive	<ul style="list-style-type: none"> <li>Light external and internal doors, air locks, panic doors, doors for emergency and escape routes.</li> <li>Slender design, compact configuration.</li> <li>Excellent reliability, door leaf weights max. 1 × 120 kg/2 × 100 kg.</li> </ul>
iMotion 2202 sliding door drive	<ul style="list-style-type: none"> <li>External and internal doors, air locks, panic doors, doors for emergency and escape routes.</li> <li>Slender design, compact configuration.</li> <li>Excellent reliability, door leaf weights max. 1 × 130 kg/2 × 120 kg.</li> </ul>
iMotion 2301 sliding door drive	<ul style="list-style-type: none"> <li>External and internal doors, air locks, panic doors, doors for emergency and escape routes.</li> <li>High pedestrian frequencies, long working life.</li> <li>Low noise leaf movements, door leaf weights max. 1 × 150 kg/2 × 130 kg.</li> </ul>
iMotion 2401 sliding door drive	<ul style="list-style-type: none"> <li>External and internal doors, air locks, panic doors, doors for emergency and escape routes.</li> <li>The heaviest door leaf weights, long working life.</li> <li>Dynamic door leaf movements, door leaf weights max. 1 × 450 kg/2 × 300 kg.</li> </ul>

## Installation Information

<b>Basic principles</b>	<ul style="list-style-type: none"> <li>The system must be commissioned at least in accordance with DIN 18650 and only by an installation specialist trained by the manufacturer.</li> <li>Avoid direct exposure of the automated door equipment to sun, snow and rain.</li> </ul>														
<b>Space required</b>	<table border="1"> <thead> <tr> <th>Drive unit</th> <th>Win Drive 2201 iMotion 2202</th> <th>WD 2201 Telescope iM 2202 Telescope</th> <th>iMotion 2301</th> <th>iM 2301 Telescope</th> <th>iMotion 2401</th> <th>iM 2401 Telescope</th> </tr> </thead> <tbody> <tr> <td><b>Section (H × T) mm</b></td> <td>100 × 142</td> <td>100 × 204</td> <td>200 × 155</td> <td>200 × 245</td> <td>200 × 185</td> <td>200 × 275</td> </tr> </tbody> </table>	Drive unit	Win Drive 2201 iMotion 2202	WD 2201 Telescope iM 2202 Telescope	iMotion 2301	iM 2301 Telescope	iMotion 2401	iM 2401 Telescope	<b>Section (H × T) mm</b>	100 × 142	100 × 204	200 × 155	200 × 245	200 × 185	200 × 275
Drive unit	Win Drive 2201 iMotion 2202	WD 2201 Telescope iM 2202 Telescope	iMotion 2301	iM 2301 Telescope	iMotion 2401	iM 2401 Telescope									
<b>Section (H × T) mm</b>	100 × 142	100 × 204	200 × 155	200 × 245	200 × 185	200 × 275									
<b>Power connection</b>	<ul style="list-style-type: none"> <li>1 × 230/1 × 115 V AC (+5 %/–10%), 50–50 Hz, 10 A.</li> <li>Install the power plug directly adjacent to the drive.</li> <li>Connection uses a commercial power cable with a connector for non-heating apparatus.</li> <li>Only use earthed/grounded connectors.</li> <li>The mains cable must be secured against becoming tangled with the moving parts of the drive or door system.</li> <li>Adjust all necessary components to the maximum available power during the planning process. Provide an additional external 24 V power supply if additional power is needed.</li> <li>Provide optional battery unit for power failures.</li> </ul>														
<b>Safety</b>	<ul style="list-style-type: none"> <li>Reduce speeds to avoid surprising users.</li> <li>Control system with integral obstacle recognition in order to avoid serious injuries if the sensor system should fail.</li> <li>Emergency and escape routes/fire protection – see page 20.</li> </ul>														
<b>Protection against the main closing edge</b>	<ul style="list-style-type: none"> <li>Protect with a monitored light curtain.</li> <li>Motion detectors must cover the entire area in front of the door so that persons can be detected in good time and without contact in order to avoid endangering persons with poor reaction capabilities.</li> <li>If the pushing of the button is done via specific to activated actuators such as push-buttons, the radar section of the combi-sensor should be programmed as a time delayed impulse.</li> </ul>														
<b>Protection against the secondary closing edge</b>	<ul style="list-style-type: none"> <li>Use protection leaves or presence sensors.</li> <li>Partially sighted persons can only be protected by protection leaves as their white cane is not detected by normal sensor systems.</li> </ul>														
<b>Operation</b>	<ul style="list-style-type: none"> <li>Maximum cable length from drive to button, key switch or user interface 30 m.</li> <li>Do not install close to any secondary closing edge safety equipment.</li> </ul>														
<b>Door leaves</b>	<ul style="list-style-type: none"> <li>Door fillings available in all variants: various glasses (toughened safety glass, laminated safety glass and insulating glass), wood, metal and plastic. Door leaves can be framed by profiles – clear anodised, stove enamelled or powder coated in any required colour.</li> <li>Transparent door panels considerably lower the risk of accidents caused by collisions, but they need markings according to page 7.</li> </ul>														

# Passageways with Turnstile Revolving Doors

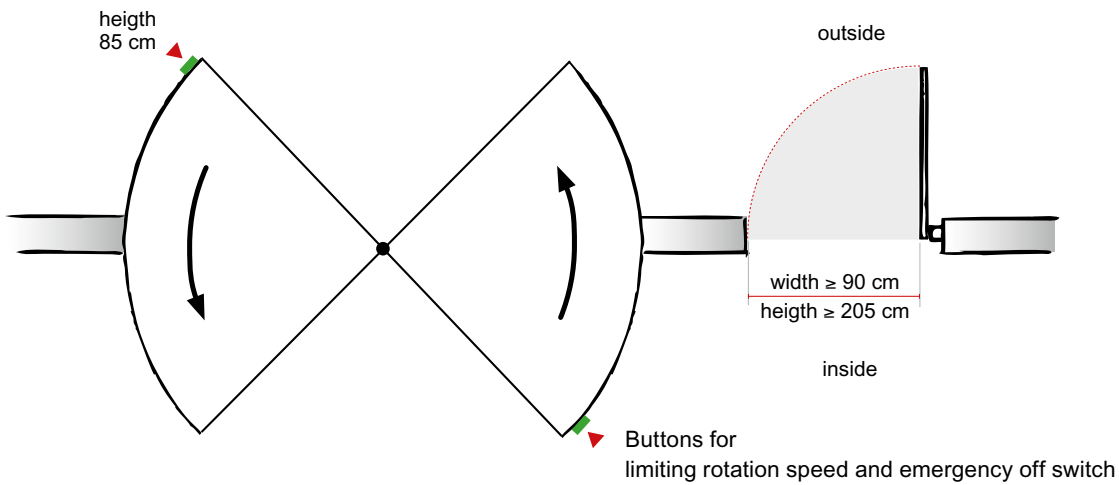

Plan view of entrance/exit

## Safety/Sensor Technology

Impulse fields and hazardous areas where protection is needed

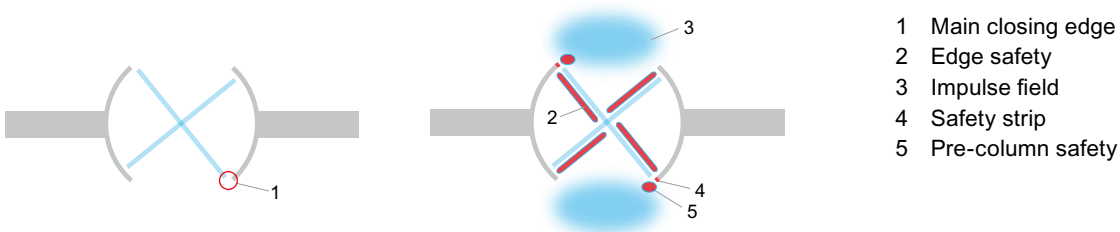

## Door Designs

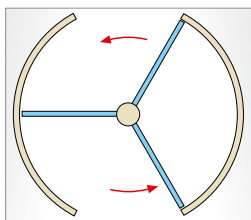
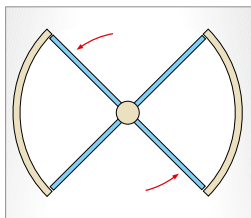

Type	Number of leaves	Diameter for barrier-free access
CL small	3 leaves	Suitable for 3.4 – 4.0 m
	4 leaves	Suitable for 3.8 – 4.0 m
CL large	3 leaves	Suitable for 3.6 – 6.0 m
	4 leaves	Suitable for 3.8 – 6.2 m
LF	3 leaves	Suitable for 3.4 – 3.6 m

# Automated Door Equipment

Product	Suitability/ special features
CLASSIC (CL) small	<ul style="list-style-type: none"> <li>• Classic turnstile revolving door with a diameter of up to 4 m. 3 or 4 leaves, also available as option with swivelling leaves. Excellent safety equipment.</li> <li>• Drive installed in the crown. Clear passage height from 2.10 m.</li> <li>• Note minimum diameter for wheel-chairs (Ø 3.4 m).</li> </ul>
CLASSIC (CL) large	<ul style="list-style-type: none"> <li>• Classic turnstile revolving door with diameter 3.6 – 6.2 m. Also suitable for high pedestrian frequency and shopping trolleys. 3 or 4 leaves with swivelling leaves. Excellent safety equipment.</li> <li>• Drive installed in the crown.</li> <li>• Clear passage height from 2.10 m.</li> </ul>
LIGHT FRAME (LF)	<ul style="list-style-type: none"> <li>• Turnstile revolving door with slender frame and plenty of glass. The roof is also made of glass as the drive is installed in the floor or ceiling. 3 or 4 leaves. Also available as option with swivelling leaves.</li> <li>• Clear passage height from 2.10 m</li> <li>• Note minimum diameter for wheel-chairs.</li> </ul>
FULL GLASS (FG)	<ul style="list-style-type: none"> <li>• Not suitable as the maximum diameter is too small.</li> </ul>

## Installation Information

<b>Basic principles</b>	<ul style="list-style-type: none"> <li>• The system must be commissioned at least in accordance with DIN 18650 and only by an installation specialist trained by the manufacturer.</li> <li>• Install button for limiting speed of rotation and emergency off switch at height of 0.85 m.</li> <li>• It is essential to design an additional door (swing door, sliding door) very close to the turnstile revolving door as the latter are not suitable for blind persons and possibly also not for the visually impaired.</li> </ul>
<b>Power connection</b>	<ul style="list-style-type: none"> <li>• 1 × 230/1 × 115 VAC (+5 %/– 10%), 50–50 Hz, 10 A.</li> <li>• Install the power plug adjacent to the drive.</li> <li>• Connection uses a commercial power cable with a connector for non-heating apparatus.</li> <li>• Only use earthed/grounded connectors.</li> <li>• The mains cable must be secured against becoming tangled with the moving parts of the drive or door system.</li> <li>• Provide optional battery unit for power failures.</li> </ul>
<b>Safety</b>	<ul style="list-style-type: none"> <li>• Reduce speeds to avoid surprising users.</li> <li>• Control system with integral obstacle recognition in order to avoid serious injuries if the sensor system should fail.</li> </ul>
<b>Protection against the main closing edge</b>	<ul style="list-style-type: none"> <li>• Protect the pre-column and the main closing edges with a safety strip and monitored light curtain.</li> <li>• Motion sensors must cover the entire area in front of the door so that persons are recognised in good time and without contact in order to avoid endangering persons with poor reaction capabilities.</li> </ul>
<b>Protection against the door leaves</b>	<ul style="list-style-type: none"> <li>• Edge safety: protect the door leaves with a safety strip</li> </ul>
<b>Operation</b>	<ul style="list-style-type: none"> <li>• Maximum cable length from drive to button, key switch or user interface 30 m.</li> </ul>

# Passageways with Folding Doors

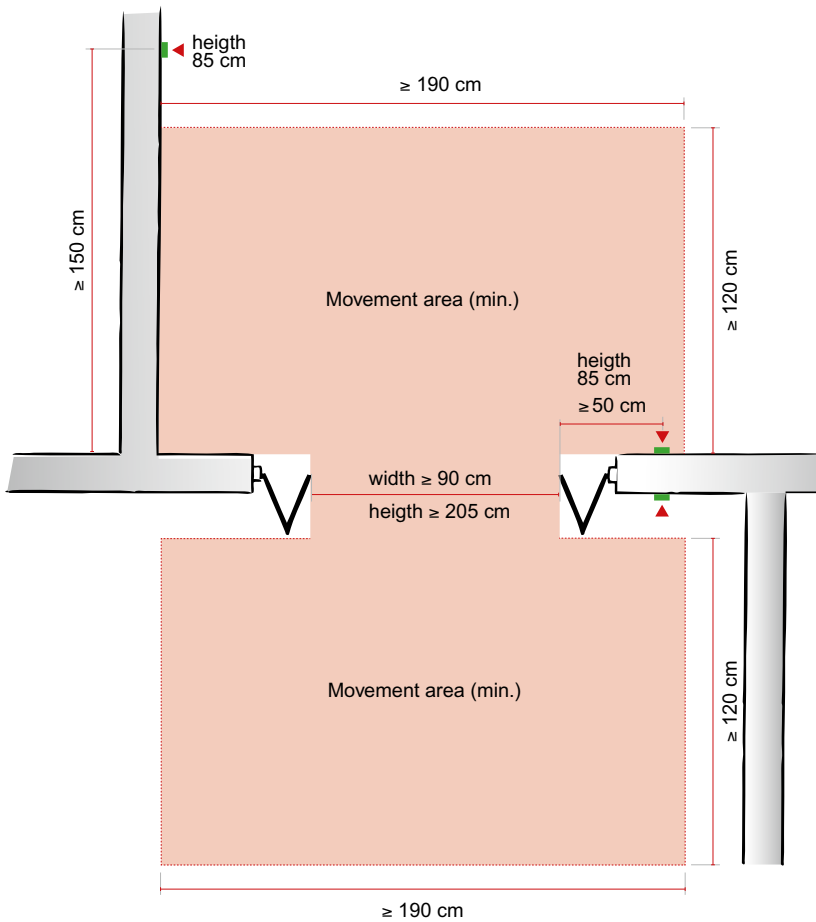

## Safety / Sensor Technology

Impulse fields and hazardous areas needing protection



- 1 Main closing edge
- 2 Secondary closing edge
- 3 Impulse fields
- 4 Safety field
- 5 Moving safety feature

## Door Design



Plan view of entrance/exit



# Automated Door Equipment

Product/drive	Suitability/special features
Foldor TOP	<ul style="list-style-type: none"> <li>• When space is limited</li> <li>• Particularly suitable for installation in buildings being converted or renovated.</li> <li>• Installation in passageways or surface-mounted installation.</li> <li>• Electromagnetic locking</li> <li>• Integrated emergency opening system</li> <li>• Max. door leaf weight = 2 × 80 kg</li> </ul>

## Installation Information

<b>Basic principles</b>	<ul style="list-style-type: none"> <li>• The system must be commissioned at least in accordance with DIN 18650 and only by an installation specialist trained by the manufacturer</li> <li>• Avoid direct exposure of the automated door system to sun, snow and rain.</li> </ul>
<b>Unrestricted passage width</b>	<ul style="list-style-type: none"> <li>• 900 to 1400 mm</li> </ul>
<b>Min. system length mm</b>	<ul style="list-style-type: none"> <li>• Opening width +260 mm</li> </ul>
<b>Cross section (H × T) mm</b>	<ul style="list-style-type: none"> <li>• 120 × 250 mm</li> </ul>
<b>Power connection</b>	<ul style="list-style-type: none"> <li>• 1 × 230/1 × 115 VAC (+5 %/– 10%), 50–50 Hz, 10 A.</li> <li>• Install the power plug directly adjacent to the drive.</li> <li>• Connection uses a commercial power cable with a connector for non-heating apparatus.</li> <li>• Only use earthed/grounded connectors.</li> <li>• The mains cable must be secured against becoming tangled with the moving parts of the drive or door system.</li> <li>• Provide optional battery unit for power failures.</li> </ul>
<b>Safety</b>	<ul style="list-style-type: none"> <li>• Reduce speeds to avoid surprising users.</li> <li>• Control system with integral obstacle recognition in order to avoid serious injuries if the sensor system should fail.</li> </ul>
<b>Protection against the main closing edge</b>	<ul style="list-style-type: none"> <li>• Motion detectors must cover the entire area in front of the door so that persons can be detected in good time and without contact in order to avoid endangering persons with poor reaction capabilities.</li> </ul>
<b>Protection against the secondary closing edge</b>	<ul style="list-style-type: none"> <li>• The secondary closing edges are secured using optimised frame profiles for the purposes of guarding fingers. Therefore, children's fingers or the white canes of visually impaired people cannot get jammed.</li> </ul>
<b>Operation</b>	<ul style="list-style-type: none"> <li>• Maximum cable length from drive to button, key switch or user interface 30 m.</li> </ul>

# Designing for Bath-Rooms and Toilets

## Basic Principles

- For safety reasons swing doors must not open into bath-rooms or toilet areas so that doors cannot be jammed.
- It must be possible to unlock doors to bath-rooms and toilets from the outside.
- A movement area of at least 150 × 150 cm is to be provided in front of sanitary objects such as WC bowls, washbasins and shower areas. If this is not structurally possible, the movement area in the interior of the WC should be extended by 0.5m on both sides.
- It must be possible to approach the WC bowl from both sides. A movement area with a minimum depth of 70 cm (from the front edge of the bowl to the rear wall and a width of min. 90 cm is necessary for this.
- It is recommended that a pull switch (emergency signal) is installed immediately to the left and right of the WC bowl so that the emergency signal can be activated when sitting on the WC and when lying on the floor.

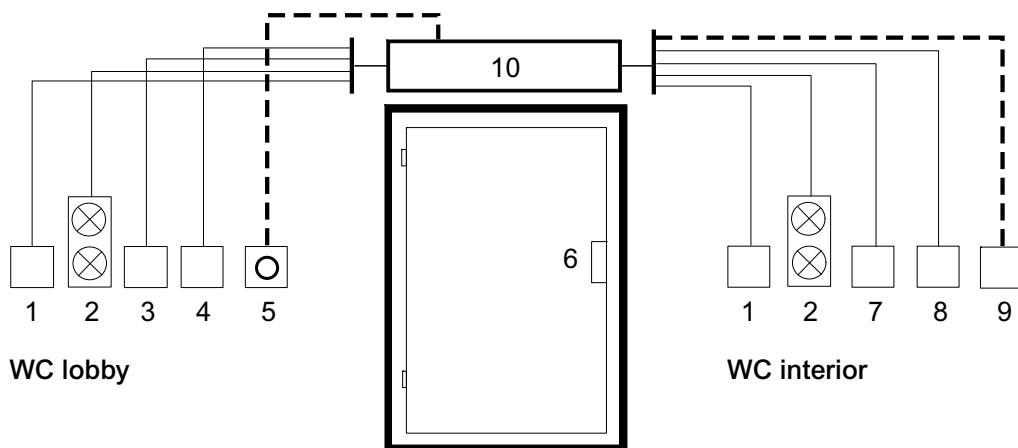

## Connections

- 1 Emergency signal
- 2 Indicator light – free/occupied
- 3 Key switch (for emergency opening)
- 4 External flush-mounted switch (with handicap symbol)
- 5 Emergency off switch (disconnects the power supply)
- 6 Lock (unlocked when power off)
- 7 Toggle switch (close door and lock; unlock door and open)
- 8 Internal flush-mounted switch
- 9 Emergency signal (pull switch)
- 10 Door drive Smart Drive 1101 or iMotion 1301

### **Sequence WITHOUT Emergency Scenario**

- a) Starting point: WC is not in use:
  - The indicator light (2) indicates that the toilet is free.
  - The toilet door is closed.
- b) The person wishing to use the toilet presses the external flush-mounted switch (4) to open the door
- c) The person wishing to use the toilet can enter the interior of the toilet in this way. The user then activates the toggle switch (7) to close and lock the door to the toilet.
- d) The indicator light (2) immediately switches to “occupied”.
- e) When the person using the toilet wants to leave the interior of the toilet, he must press the toggle switch once more to unlock the door. The user then presses the flush-mounted switch inside the toilet area (8) to open the toilet door. The indicator light (2) immediately switches back to “free”.
- f) The user can now leave the toilet.

### **Sequence WITH Emergency Scenario**

- a) Starting point:
  - The toilet door is closed and locked. The indicator light (2) shows “occupied”.
  - The toilet user has a serious problem.
- b) The toilet user pulls the pull switch (9) to raise the alarm. The “Emergency” display (1) immediately lights up. The toilet user now knows that the alarm has been successfully raised.
- c) The person coming to the aid of the person in the toilet can open the toilet door either by means of the key switch (3) or the emergency open switch (5) and assist the person inside who has summoned help.

### **Important**

The features of both control system types (Smart Drive 1101 or iMotion 1301) make them suitable for the door of toilets designed for handicapped persons.

The emergency system can be operated without additional controls / sensor technology!

If an emergency open switch is used with control device 5, a lock which is unlocked when the power is off **MUST** be used.

The emergency signal can use a separate emergency signalling system.

# Emergency and Escape Routes/Fire Protection

## General Recommendations

### Evacuation

- No steps on the route to the exit. However, if steps have to be used:
  - Evacuate using a slide which is integral with the building (problems climbing out of the slide at the bottom)
  - Evacuate using stretchers (positioned in key locations)
  - Evacuate using an evacuation chair (positioned in key locations). However, is a high-cost solution.
  - Evacuate using special fire-protected areas for stop-overs (min. 1.50 × 1.50 m) which are designed to be free from smoke and flames and which have intercoms or push buttons for emergency communication.
- Staff should be trained in the use of evacuation aids and in dealing with persons whose mobility is limited.

### Fire alarms

- Alarms should be optical or acoustic. Possibly also using vibration for the hard of hearing and the profoundly deaf.
- Provide acoustic alarms in the escape direction; sounds or sequences of sound must be clearly distinguishable. Ensure that information provided by word of mouth is perfectly understandable.

### Notes in information and guidance systems

- Plans describing escape routes should not only contain diagrams which are easily understood and be positioned in well lit and easily accessed positions, but should also be able to be discernible by auditory means and touch.
- Escape route doors should be marked in large, contrasting letters/signs as well as by a tactile → and tactile diagrams using Braille and tactile Latin letters (e.g. I.L.I.S profile script).
- Instructions which warn, guide, inform or direct should not be positioned in the same field of vision or same auditory range as instructions of a different type (e.g. advertising).
- Signs should also be installed close to the ground as gases, vapours and steam collect initially close to the ceiling as a result of thermal uplift.
- Hallways and other passageways should be equipped with an information and guidance system which is as continuous as possible. Floors, walls and doors should have high-contrast marking (possibly also screens to make people aware of an emergency.)
- In the case of large building complexes, the information and guidance system should extend to outdoor public areas.
- Corridors on each floor should be differentiated by colour e.g. differently coloured walls and floor coverings.

### Fire doors

- Existing fire doors in escape routes may only be automated if this is expressly intended, and was checked, by the brand protection certificate bearer.

### Normative references

- Basic principles for all doors: DIN 18650
- Basic principles for design: DIN 18040

### Additional literature

i-5-B, Klaus-Dieter Wüstermann, 12159 Berlin – Requirements for Barrier-free Escape Routes



INDLETT

coop  
4%  
MEDLEMS-  
BONUS  
På alle egne markter

Absningsstid  
Mandag-Fredag  
900-2100  
Lørdag  
800-1700

Absningsstid  
Mandag-Fredag  
900-2100  
Lørdag  
800-1700

## Brochures on TORMAX Automated Door Systems

### TORMAX Architects' Folder

- Image brochure
- Sliding door systems
- Curved sliding door systems
- Swing door systems
- Turnstile revolving door systems
- Door drives – product information
- Operating manuals
- Risk assessments
- Texts for invitations to tender

PDF download at [www.tormax.com](http://www.tormax.com)

## Planning and Consultancy

Please contact your architectural association, crafts council or engineering association directly for further information.

You will also be able to obtain additional information on barrier-free planning and construction at the following address:

### Centre for Barrier-free Design:

HyperJoint GmbH

Sonja Hopf (Diplom-Ingenieur, architecture)

Paul-Gesche-Strasse 8

10315 Berlin

Phone +49 30 526 96 25 0

Fax +49 30 526 96 25 1

[nullbarriere@hyperjoint.com](mailto:nullbarriere@hyperjoint.com)

[www.nullbarriere.de](http://www.nullbarriere.de)

You can also obtain information on particular disabilities from the relevant disabled persons association.





**the passion to drive doors**

**Manufacturer:**

**TORMAX** | CH-8180 Bülach-Zürich  
Phone +41 (0)44 863 51 11  
Fax +41 (0)44 861 14 74  
Homepage [www.tormax.com](http://www.tormax.com)  
E-Mail [info@tormax.com](mailto:info@tormax.com)

TORMAX is a division and registered  
trademark of Landert Motoren AG